

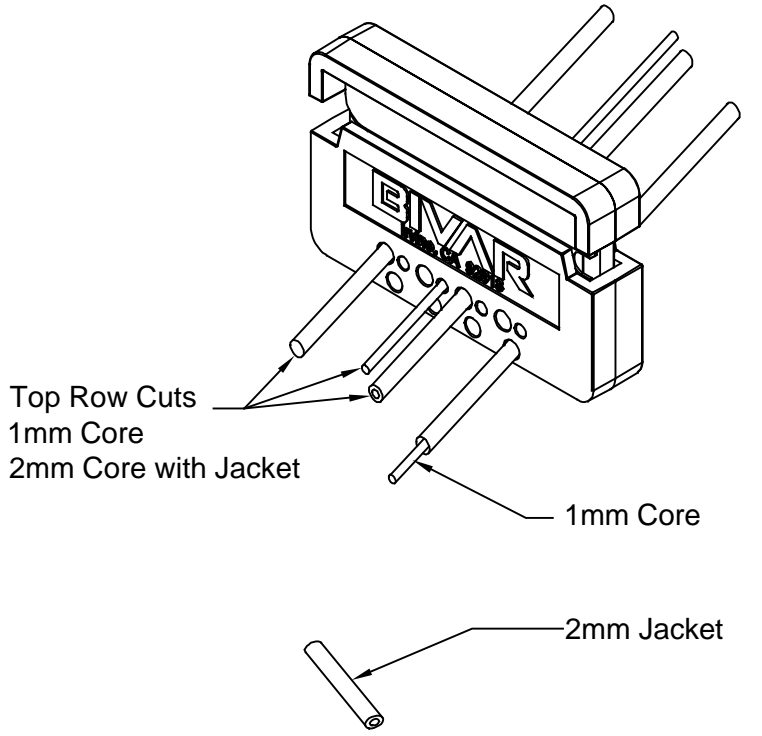

ITEM	QTY	PART NUMBER	PART DESCRIPTION
1	1	BOFC-101	Bivar Optical Fiber Cutter, Blade Holder
2	1	BOFC-102	Bivar Optical Fiber Cutter, Base
3	1	BOFC-103	Bivar Optical Fiber Cutter, Heavy Duty Razor

REV.	DESCRIPTION	DATE	APPROVED
A	Engineering Update w/o Changes	03/04/04	M. C.
B	Added Function of Holes	08/25/06	M. C.

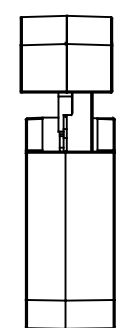
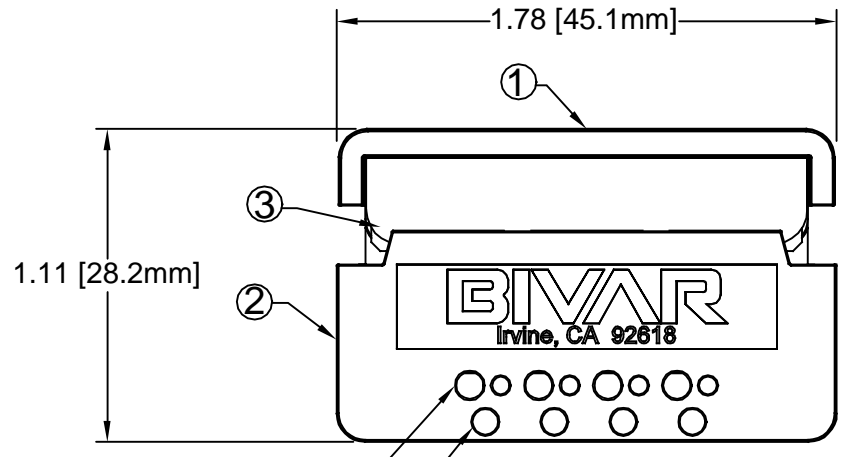
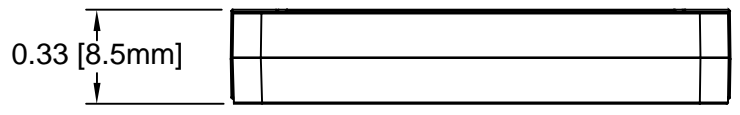

Bottom Row Strips  
2mm Core with Jacket

Top Row Cuts  
1mm Core  
2mm Core with Jacket

STANDARD TOLERANCE (UNLESS OTHERWISE SPECIFIED)		 4 THOMAS, IRVINE, CA. 92618 TEL: (949) 951-8808 FAX: (949) 951-3974		
DECIMALS	ANGULAR			
.X ± .1	X° ± 1°		TITLE: BIVAR OPTICAL FIBER CUTTER ASSY.	
.XX ± .02			PART NO: BOFC-100	REVISION: B
.XXX ± .010			CAGE CODE : 32559	SHEET # 1 OF 1
DESIGNED: <b>David Green</b>	DATE: <b>03/04/04</b>	CAD GENERATED DOCUMENT, DO NOT MEASURE DRAWING.		
CHECKED: <b>M. Chen</b>	DATE: <b>03/04/04</b>			