

REVISIONS			
REV.	DESCRIPTION	DATE	APPROVED
K	Removed Obsolete Products	10/08/09	T. Y.
M	Removed Material Code	05/28/16	J. C.
N	Changed Material to Halogen Free	10/18/19	A. V.
R	Changed Material 15%GF, ECO 1026	10/22/19	A. V.
T	Added Torque Range Note, ECO 1062	07/13/20	A. V.
U	Added Torque Range Note, ECO 1112	12/13/21	A. V.

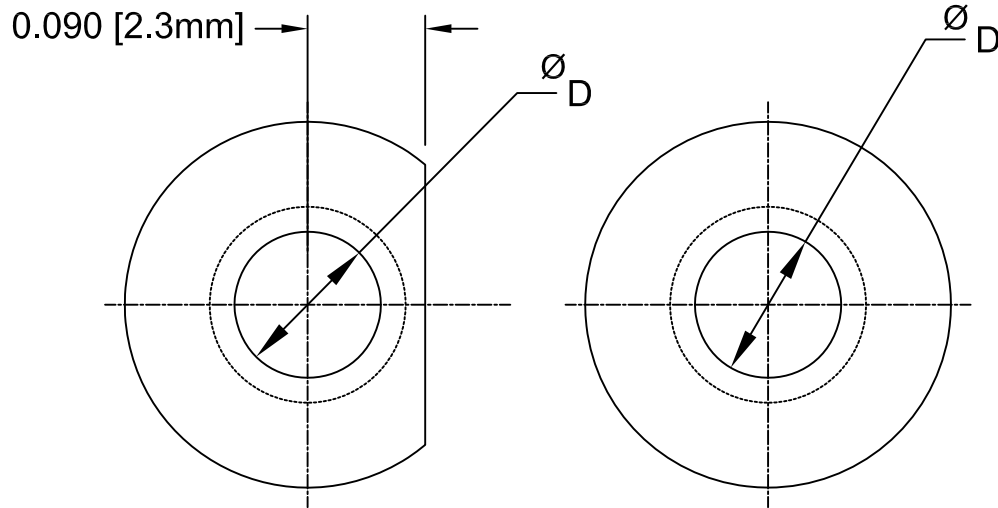
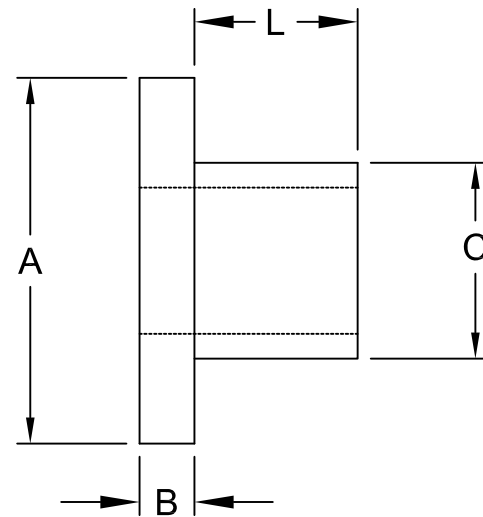

FIG. 2

FIG. 1



PART NO.	L	A	B	C	D	SCREW SIZE	FIG.	MATERIAL
SW-032-135	0.032(0.8mm)	0.215(5.5mm)	0.040(1.0mm)	0.130(3.3mm)	0.116(3.0mm)	4	1	1
SW-040-140	0.040(1.0mm)	0.245(6.2mm)	0.040(1.0mm)	0.140(3.6mm)	0.119(3.0mm)		2	
SW-125-140	0.125(3.2mm)	0.280(7.1mm)	0.042(1.1mm)	0.140(3.6mm)	0.112(2.8mm)		1	2
SW-031-145	0.031(0.8mm)	0.280(7.1mm)	0.047(1.2mm)	0.145(3.7mm)	0.118(3.0mm)			
SW-093-145	0.093(2.4mm)	0.235(6.0mm)	0.047(1.2mm)	0.140(3.6mm)	0.115(2.9mm)		1	1
SW-187-145	0.187(4.8mm)							
SW-125-150	0.125(3.2mm)	0.280(7.1mm)	0.042(1.1mm)	0.150(3.8mm)	0.112(2.8mm)		6	1
SW-185-150	0.185(4.7mm)	0.280(7.1mm)	0.042(1.1mm)	0.150(3.8mm)	0.122(3.1mm)			
SW-031-177	0.031(0.8mm)	0.312(7.9mm)	0.047(1.2mm)	0.177(4.5mm)	0.144(3.7mm)			
SW-031-190	0.031(0.8mm)	0.312(7.9mm)	0.047(1.2mm)	0.190(4.8mm)	0.146(3.7mm)			

5. SW-040-140 ACCEPTABLE TORQUE RANGE: 300-400 mN-m.
4. SW-032-135 ACCEPTABLE TORQUE RANGE: 300-400 mN-m.
3. MATERIAL 2: NYLON 6/6, 94V-0, BLACK.
2. MATERIAL 1: PBT, 15% GLASS FILLED, 94V-0, BLACK.
1. GENERAL SPECIFICATIONS: BIVAR MOLDED COMPONENT SPECIFICATION BV00-E101.

STANDARD TOLERANCE (UNLESS OTHERWISE SPECIFIED)	
DECIMALS	ANGULAR
.X ±.1	X° ± 1°
.XX ±.01	
.XXX ±.005	

**BIVAR**<sup>®</sup>

4 THOMAS, IRVINE, CA. 92618  
TEL: (949) 951-8808 FAX: (949) 951-3974

TITLE:  
HIGH TEMPERATURE SHOULDER WASHER

DESIGNED: D. GREEN	DATE: 01/17/03	DRAWING NO: SW-XXX-XXX	REVISION: U
REVISED: E. CHAN	DATE: 12/13/21	SHEET SIZE A	CAGE CODE: 32559
CHECKED: A. VALDEZ	DATE: 12/13/21	SCALE: NONE	SHEET # 1 OF 1

CAD GENERATED DOCUMENT, DO NOT MEASURE DRAWING